



## Full Length Research Article

### Z-SOURCE ISOLATED BIDIRECTIONAL DC-DC CONVERTER

**\*Gujjari Chandra**

Department of Electrical and Electronics Engineering, Anurag College of Engineering, Aushapur, Hyderabad

#### ARTICLE INFO

##### Article History:

Received 24<sup>th</sup> June, 2016  
Received in revised form  
17<sup>th</sup> July, 2016  
Accepted 19<sup>th</sup> August, 2016  
Published online 30<sup>th</sup> September, 2016

##### Key Words:

Bidirectional dc-dc converter (BDC),  
Coordinated control,  
Double-closed loop,  
Z-source.

#### ABSTRACT

In This paper, a Bidirectional DC-DC converter also known as dual active bridge (DAB) dc-dc converter is presented. A Z-source with bidirectional dc-dc converter by reducing the switching count by adding passive elements has improved the output voltage level, when compared with the traditional bidirectional dc-dc converter. The proposed converter has a wider regulation range of voltage. The fully bridge symmetrical circuit configuration, is neither a high-voltage side nor a low-voltage side in the circuit structure, and the sources connected to the dc side of each H-bridge circuit with voltage sources and current sources. This method can reduce current stress and improves the system efficiency. Simulation results are shown by using MATLAB software.

*Copyright©2016, Gujjari Chandra. This is an open access article distributed under the Creative Commons Attribution License, which permits unrestricted use, distribution, and reproduction in any medium, provided the original work is properly cited.*

#### INTRODUCTION

BIDIRECTIONAL dc-dc converter (BDC) is a two quadrant operating dc-dc converter. It is also known as dual active bridge converter. With the increasing need for electric power in future automobiles there is an increasing requirement for bidirectional DC/DC[1] converters to transfer energy between different voltage levels i.e high voltage side and low voltage, such as between the low voltage accessories and the high voltage drive train. The hybrid system input sources like solar, fuel cells (FCs) and super capacitor (SCs) as an environmentally renewable energy system has been applied in many fields, such as hybrid electric vehicle, uninterruptible power supply (UPS). Thus, a secondary power source is required to compensate the power difference between the fuel cell and the load, and a battery is generally used to supply a transient power. The power flow between the fuel cell and the battery is managed by a bidirectional dc/dc converter. Conventional isolated bidirectional dc/dc converters for high-power applications have a voltage-fed full-bridge (FB) (VF-FB) method in the high-voltage (HV) side and various current-fed (CF) schemes in the low-voltage (LV) side in general

because voltage-fed half-bridge (HB) and voltage-fed push-pull (PP) schemes have disadvantages of high current stress and/or high voltage stress. A two-stage isolated/bidirectional dc/dc converter adopting a current ripple reduction technique is proposed. The resonant converter with two bridges takes in charge of electrical isolation and constant gain, and the bidirectional control is accomplished using only the second stage with a single bridge. To reduce rms currents in the HV source and link capacitor, capacitor division and synchronizing operation of two stages are adopted. The isolated BDC (IBDC) is needed to provide absolute electrical isolation between the primary side and the secondary side for protecting the equipment and operators IBDC is usually based on the single phase and H-bridge topology with an isolation transformer. Fig. 1 shows a typical configuration of Bidirectional DC-DC converter.

From the aspect of circuit structure, it has the following points are:

- The high-frequency transformer provides the required isolation and voltage matching between two voltage levels;
- Transformer voltage ratio is not one, and both sides of the circuit are defined as the high-voltage side compared to the low-voltage side, which makes the

**\*Corresponding author: Gujjari Chandra**

Department of Electrical and Electronics Engineering, Anurag College of Engineering, Aushapur, Hyderabad

installation location of power sources for both sides not interchangeable;

- The sources connected to the dc side of each H-bridge can only be voltage sources; and
- The transformer’s leakage inductance serves as the instantaneous energy storage device.

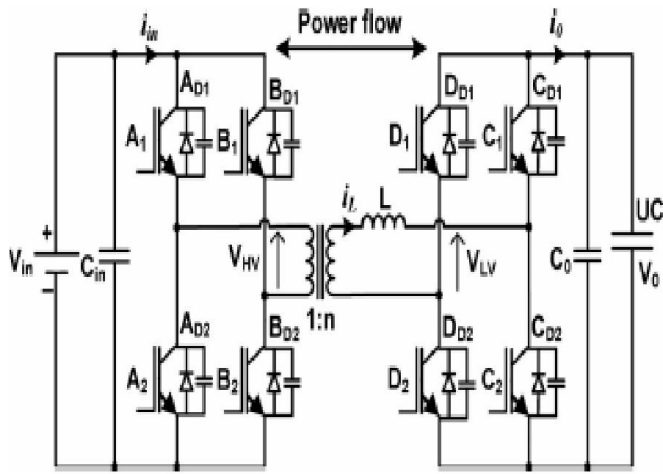
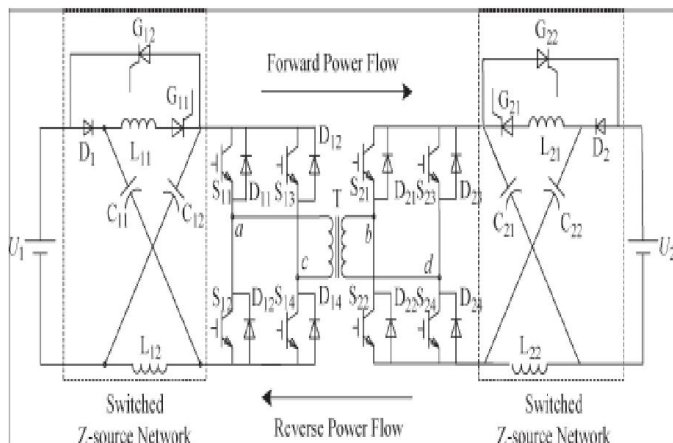

Fig. 1. Schematic of the DAB dc-dc converter

This paper presented a Bidirectional DC-DC [1]converter is also known as dual active bridge (DAB) dc-dc[1]converter. We presented a Z-source with bidirectional dc-dc converter by reducing the switching count by adding a passive elements we are going to increases the output voltage level, Comparing with the traditional bidirectional dc-dc converter, the proposed converter has an wider regulation range of voltage and many application based converter for hybrid vehicles and for any hybrid application. The fully bridge symmetrical circuit configuration, is neither a high-voltage side nor an low-voltage side in the circuit structure, and the sources connected to the dc side of each H-bridge circuit with voltage sources and current sources. This method can reduce current stress and improves the system efficiency.



**Model of dab converter**

**Basic Principle of Operation**

In Fig. 1 consists of two full-bridge circuits connected through an isolation transformer and a coupling inductor L, which may

be provided partly or entirely by the transformer leakage inductance. The full bridge on the left hand side of Fig. 1 is connected to the HV dc bus and the full bridge on the right hand side is connected to the low-voltage (LV) side. Each bridge is controlled to generate an HF square-wave voltage at its terminals. By incorporating an appropriate value of coupling inductance, the two square-waves can be suitably phase. Shifted with respect to each other to control power flow from one dc source to another. Thus, bidirectional power flow is enabled through a small lightweight HF transformer and inductor combination, and power flows from the bridge generating the leading square-wave. Although various modes of operation of the DAB converter have been presented for high power applications the square-wave mode is supposedly the best Operating mode.

This is because imposing quasi-square-wave on the transformer primary and secondary voltages results in trapezoidal, triangular, and sinusoidal waveforms of inductor current in the bidirectional DC-DC converter. These modes are beneficial for extending the low-power operating range of the converter. Although these modes tend to reduce the switching losses, the voltage loss is significant due to zero voltage which reduces the effective power transfer at high-power levels. The key operating waveforms of the converter during buck mode, i.e., when power flows from the HV side to the LV side are shown. The voltages generated by the two full bridges,  $V_{HV}$  on the HV side and  $V_{LV}$  on the LV side, are represented as square-wave voltages with 50% duty cycle. But proposed circuit is with Z sources network i.e Switched Z-sources bidirectional DC-DC converter

**Boost Model**

According to the analysis, the upper and lower devices of each phase leg in both H-bridges can be gated on simultaneously, so its reliability is improved greatly. Furthermore, the shoot-through zero state brings the boost ability to the Z sources We also take the forward power flow as an example to analyze. Assuming that the inductors  $L_{11}$  and  $L_{12}$  and capacitors  $C_{11}$  and  $C_{12}$  have the same inductance and capacitance, respectively, the Z-source network becomes symmetrical. From the symmetry and the equivalent circuits, we have (3)

$$U_{c11} = U_{c12} = U_c$$

$$U_{L11} = U_{L12} = U_L$$

we have,

$$U_L = U_1 - U_C$$

$$U_d = U_1$$

$$U_i = U_C - U_L = 2U_C - U_1$$

Where  $ud$  is the dc-link voltage of the switched Z-source network and  $ui$  is the dc-link voltage of the H-bridge we have,

$$U_L = U_C$$

$$U_d = 2U_C$$

$$U_i = 0$$

Given that a switching cycle  $T$  of SZIBDC consists of two sections,  $T_0$  for the shoot-through zero state and  $T_1$  for the normal switch state and the open zero state, respectively, the average voltage of the inductor over one switching cycle should be zero in steady state; thus, from (3) to (8), we have

$$U_L = U_L = [ T_0 \cdot U_C + T_1 \cdot ( U_1 - U_C ) ] / T = 0$$

where  $T = T_0 + T_1$ , in which case (9) can then be expressed as

$$\frac{U_C}{U_1} = \frac{T_1}{T_1 - T_0}$$

In the normal switch state and the open zero state, by substituting (10) into (5),  $u_i$  can be expressed as

$$u_i = \frac{T}{T_1 - T_0} U_1 = \frac{\pi}{\pi - 2\alpha} U_1$$

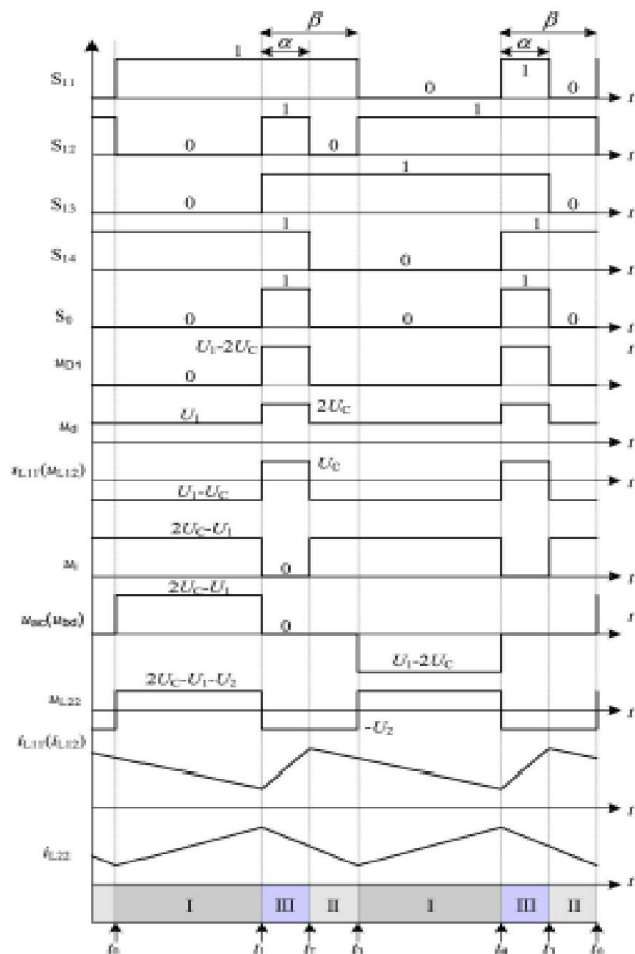

Fig. 3. Main waveforms of SZIBDC in phase-shifting shoot-through control

**Voltage Regulation Model**

In the traditional Z-source inverter, the regulation of voltage is achieved by the modulation index  $M$  and boost factor  $B$  which is unfit for the PWM in the SZIBDC. Considering this, this paper presents a phase-shifting shoot through control method. Combining with the analysis of Section II, the main waveforms of SZIBDC in phase-shifting shoot-through control are shown in Fig. 6, where the transformer voltage ratio is one,  $S_0$  is the shoot-through pulse,  $u_{D1}$  is the voltage of the diode  $D_1$ ,  $u_{ac}$  and  $u_{bd}$  are the voltages of the primary and secondary sides of the transformer, respectively, and  $i_{L11}$ ,  $i_{L12}$ , and  $i_{L22}$  are the currents flowing through the inductors  $L_{11}$ ,  $L_{12}$ , and  $L_{22}$ , respectively. In the traditional phase-shifting control

of the H-bridge, the converter is in the open zero state for an interval  $(t_0-t_2, t_3-t_5)$ . By regulating the width of the interval during a switching cycle, the average output voltage can be stepped down.  $(t_1-t_2, t_4-t_5)$  in the open zero state is added, the average output voltage can be stepped up. Note that the shoot-through zero states are evenly allocated into each phase and it does not change the total zero-state time interval. That is, the active states are unchanged.

**RESULTS**

This paper presented a Z-sources with Bidirectional DC-DC converter. We presented a Z-source with bidirectional dc-dc [6] converter by reducing the switching count by adding an passive elements to improve the system efficiency, we are going to increases level of output voltage, Comparing with the traditional bidirectional dc-dc[6] converter, the proposed converter has an wider regulation range of voltage and many application based converter for hybrid vehicles and for any hybrid application.

**Simulation circuit of an forward mode**

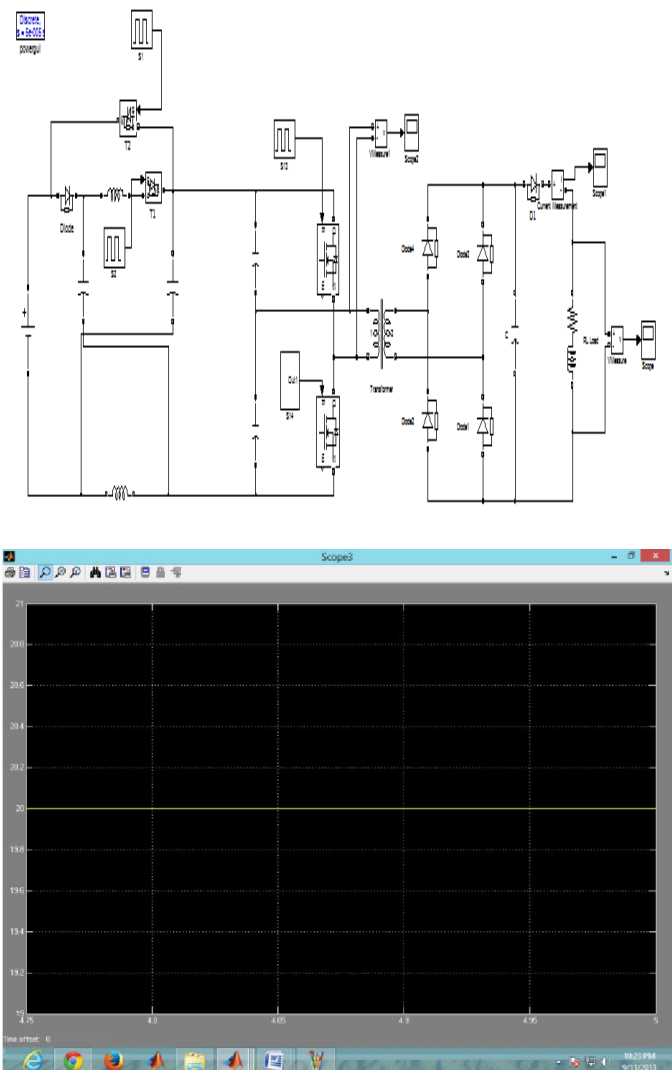

Fig.4. Input voltage waveform

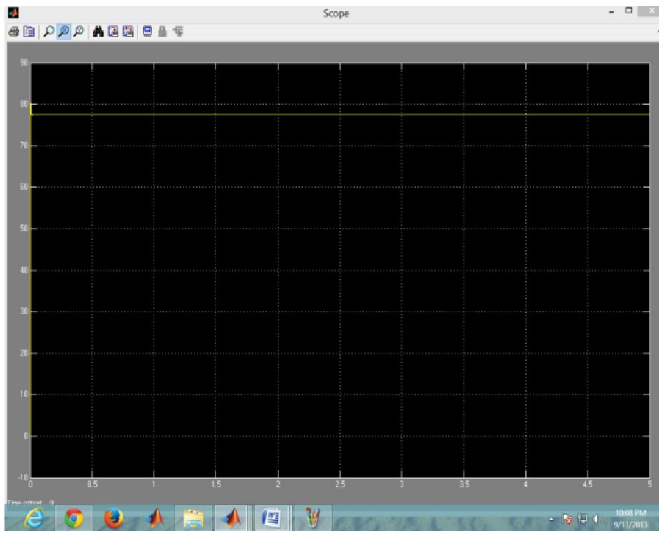

Fig. 5. Output voltage waveform

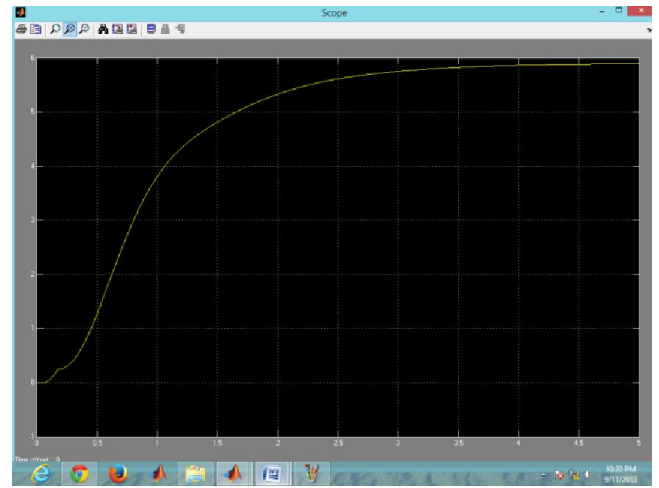

Fig.7. Output voltage of an reverse mode

Simulation circuit of reverse mode

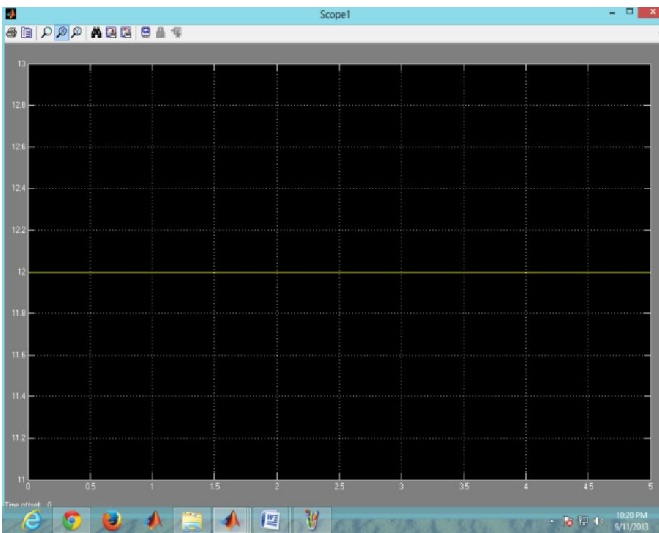
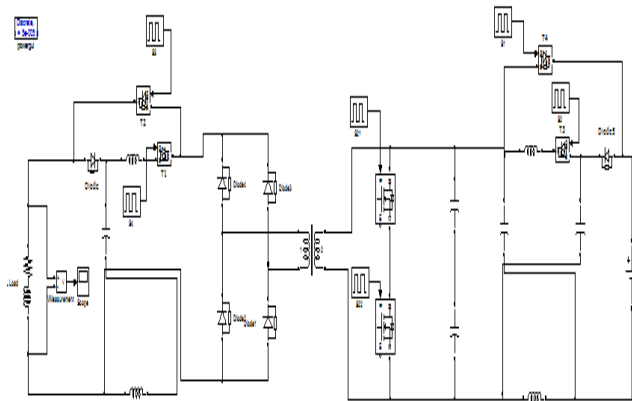

Fig.6. Input voltage in reverse mode

The fully bridge symmetrical circuit configuration, is neither a high-voltage side nor an low-voltage side in the circuit structure, and the sources connected to the dc side of each H-bridge circuit with voltage sources and current sources. This method can reduce current stress and improves the system efficiency.

Conclusion

A Z-source with bidirectional dc-dc [6]converter by reducing the switching count by adding an passive elements has widely tested and observed that there is an improvement in the output voltage level when compared with the traditional bidirectional dc-dc[6] converter. The proposed converter has been found to have a wider regulation range of voltage. This method is successful in achieving improved system efficiency and can reduce current stress. Simulation results were shown by using MATLAB software.

REFERENCES

Shahin, A., Hinaje, M., Martin, J. P. and Pierfederici, S., Rael, S. and B. Davat, 2010. "High voltage ratio dc-dc converter for fuel-cell applications," *IEEE Trans. Ind. Electron.*, vol. 57, no. 12, pp. 3944–3955, Dec.

Bascope, R. P. T., Oliveira, D. S., Branco, C. G. C. and Antunes, F. L. M. 2008. "A UPS with 110 V/220 V input voltage and high-frequency transformer isolation," *IEEE Trans. Ind. Electron.*, vol. 55, no. 8, pp. 2984–2996, Aug.

Vinnikov, D. and Roasto, I. 2011. "Quasi-Z-source-based isolated dc/dc converters for distributed power generation," *IEEE Trans. Ind. Electron.*, vol. 58, no. 1, pp. 192–201, Jan.

Peng, F. Z., Li, H., Su, G. J. and Lawler, J. S. 2004. "A new ZVS bidirectional dc-dc converters for fuel cell and battery application," *IEEE Trans. Power Electron.*, vol. 19, no. 1, pp. 54–65, Jan. 2004

Zhang, Z., Thomsen, O. C. and M. A. E. Andersen, 2011. "A novel dual-input isolated current-fed DC/DC converter for renewable energy system," in *Proc. IEEE 26th Appl. Power Electron. Conf. Expo.*, Mar. pp. 1494–1501.

Liu, W., Chen, J., Liang, T., Lin, R. and Liu, C. 2010. "Analysis, design, and control of bidirectional cascaded configuration for a fuel cell hybrid power system," *IEEE Trans. Power Electron.*, vol. 25, no. 6, pp. 1565–1575, Jun.

Bauman, J. and Kazerani, M. 2008. "A comparative study of fuel-cell battery, fuel-cell-ultracapacitor, and fuel-cell-battery-ultracapacitor vehicles," *IEEE Trans. Veh. Technol.*, vol. 57, no. 2, pp. 760–769, Mar.

\*\*\*\*\*