



ISSN: 2230-9926

Available online at <http://www.journalijdr.com>

IJDR

International Journal of Development Research

Vol. 11, Issue, 06, pp. 47872-47876, June, 2021

<https://doi.org/10.37118/ijdr.22113.06.2021>

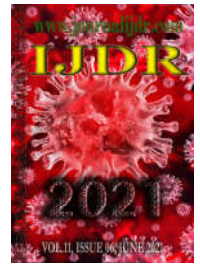

RESEARCH ARTICLE

OPEN ACCESS

PREDICTION OF THE BEHAVIOR OF ENCAPSULATED ROLLERS IN A HOT TAPER ROLLING PROCESS OF PARABOLIC LEAVES

José Airton Rodrigues de Souza¹ and Nelson Wilson Paschoalinoto^{*2}

¹Thyssen Krupp Springs & Stabilizers, Faculty of Mechatronic Technology, National Service for Industrial Training (SENAI-SP), São Caetano do Sul, SP, Brazil

²Department of Production Engineering, University Center of Maua Institute Technology, São Caetano do Sul, SP, Brazil

ARTICLE INFO

Article History:

Received 20th March, 2021

Received in revised form

19th April, 2021

Accepted 20th May, 2021

Published online 26th June, 2021

Key Words:

CAE, Hot rolling, Taper rolling, Parabolic leaf spring.

*Corresponding author:

Nelson Wilson Paschoalinoto

ABSTRACT

The automotive industry is increasingly demanding lean processes. In the heavy vehicles sector, new concepts are being sought for suspension leaf springs, with a particular focus on reduction in the vehicle mass. CAE simulation software has been used to support the design of new products and to update old designs with higher levels of confidence, thus reducing the development time and cost. This article reports the effectiveness of CAE simulation in confirming the technical viability of a new encapsulated roller kit, which was designed to replace the use of traditional single-piece solid rollers, imported from Germany, in a hot rolling process for parabolic leaf springs, with the aim of obtaining economic and environmental benefits.

Copyright © 2021, José Airton Rodrigues de Souza and Nelson Wilson Paschoalinoto. This is an open access article distributed under the Creative Commons Attribution License, which permits unrestricted use, distribution, and reproduction in any medium, provided the original work is properly cited.

Citation: Souza, J. A. R. and Paschoalinoto, N. W. "Prediction of the behavior of encapsulated rollers in a hot taper rolling process of parabolic leaves", *International Journal of Development Research*, 11, (06), 47872-47876.

INTRODUCTION

The increasing competitiveness of automotive marketing has given rise to a demand for more productive and lean processes, from the most basic levels of the production chain. In the heavy vehicles sector, there is a demand for the development of parabolic leaf springs for suspension systems that can contribute to reducing vehicle mass, with consequent reductions in manufacturing costs, fuel consumption and carbon emissions to the atmosphere. The use of virtual simulation software applications has undergone an expansion in terms of the development of products and manufacturing processes, as they can reduce development costs and time to market (Jurgens, 2000) by replacing time-consuming and costly prototyping processes. This competitive environment has forced the auto parts sector to constantly search for alternatives in order to continuously improve the efficiency of the production chain, and in the specific case of the manufacture of parabolic leaf springs, this translates, for example, into a need to shorten the development times for rolling tools and

reduce their cost (Cetlinand Helman, 2005). In this context, CAE (computer aided engineering) software has also been gaining popularity as a tool for preventing failures and error, and hence for validating the design of the manufacturing process and predicting its behavior in a production environment through simulation. According to Siemens (2015), CAE software is intended to simulate and help solve engineering problems in a wide variety of sectors, including the simulation, validation and optimization of products and processes and the manufacture of tooling. CAE design can provide a reliable diagnosis in the initial stages of development, in which design changes are more economically viable, thus allowing for earlier resolution of problems and reductions in both the development costs and those related to the product lifecycle. Oliveira and Ferreira (2016) state that through CAE analysis, "it is possible to evaluate the design of the components in their applications, simulating the efforts suffered in the work environment, visualize their weak points and apply possible changes to increase the reliability of the part." The present work focuses on an object used in a rolling process. This is a conformation process that consists of the passage of a billet (a piece of steel material to be rolled) between two cylindrical bodies, which

are tools that rotate at the same speed but in opposite directions (Cetlinand Helman, 2005). There are two types of rolling process, cold rolling and hot rolling, and the choice of one of these approaches depends on the type of material to be rolled (in terms of its metallographic structure and mechanical properties) and the initial and final dimensions of the rolled material. In hot rolling (the focus of this study), the thermal cycle is such that the processing temperature is kept above the temperature of recrystallization of the processed steel (Cetlinand Helman, 2005). Figure 1 shows a schematic illustration of the hot rolling process. For a better understanding of the function of the tool that forms the object of this study, it is necessary to describe the hot rolling system and its operation. The system is basically composed of a heating oven, a rolling mill and the rolling cradle set that accommodates the tool (the rolling mill). Figure 2 shows the details of the rolling mill, which is mounted on the cradle of the rolling machine.

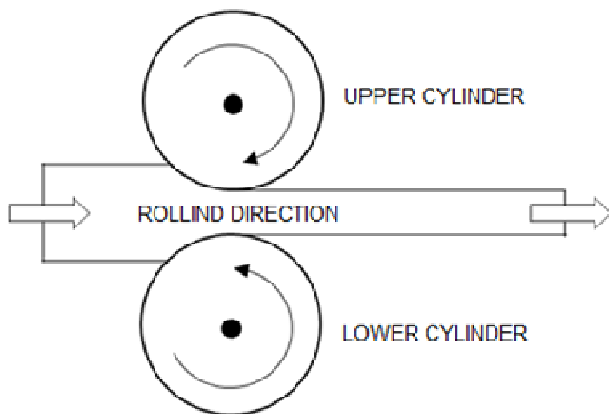

Figure 1. Hot rolling



A



B

Figure 2. The hot rolling system: (a) overview of the rolling line; (b) detail of the rolling mill

Table 1. Mesh parameters used

Piece	Component	Size	Sag
1	Shaft	5.0	2.0
2	Cover	6.0	2.0
3, 4	key	2.53	0.41

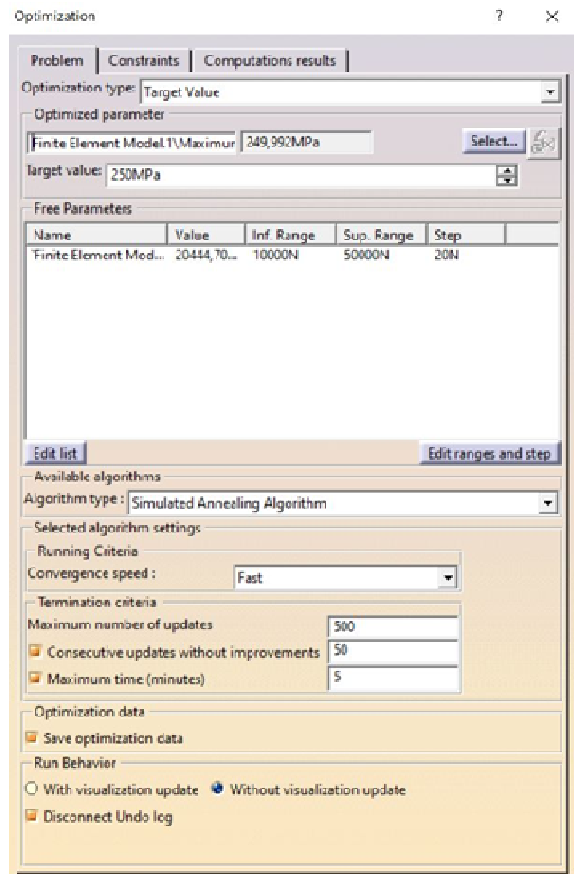

Figure 3. Optimizer module tool

In this study, we explore the technical and economic feasibility of an encapsulated roller kit that was designed to replace the traditional one-piece roller in the hot rolling process, as a method for analyzing its behavior in the process of manufacturing parabolic leaf springs. In the current process, the roller is manufactured in one piece from imported noble steel, and therefore has a high cost. Despite this, the rolling mill, which is originally 225 mm in diameter, has a short service life, since after reaching the maximum tolerable wear limit of 7 mm in thickness, it is discarded and sold as scrap.

MATERIALS AND METHODS

The new roller proposed here consists of a shaft with a Bohler W360 steel cover and an SAE 4140 steel core, which are integrated by means of a SAE 5160 steel transmission key. During the rolling process, this set is subjected to a temperature of 1200°C while shaping the leaf in to the form of a parabola. At the end of its lifecycle, only the cover is discarded (scrapped), and the core and key of the roller are preserved, which prolongs the service life of the tool. The software used to simulate the behavior of the roller under operational conditions was the FEA module of CATIA V5 from Dassault Systèmes® (2020).

It is important to emphasize that this static study was limited to the use of CAE to optimize the design of the rolling mill tool. The development of the encapsulated roller kit project began with the original tool pattern, which had a solid geometry and was made of noble steel. The following boundary conditions were preserved: the external dimensions, the steel specifications for the back cover, and the parameters of the operational rolling process.

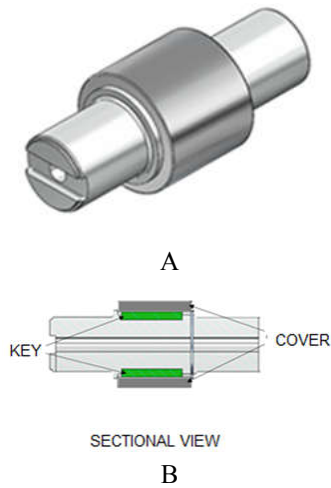

Figure 4. CAD/CAE/CAM design and manufacturing proposal: (a) solid shaft; (b) keyed shaft.

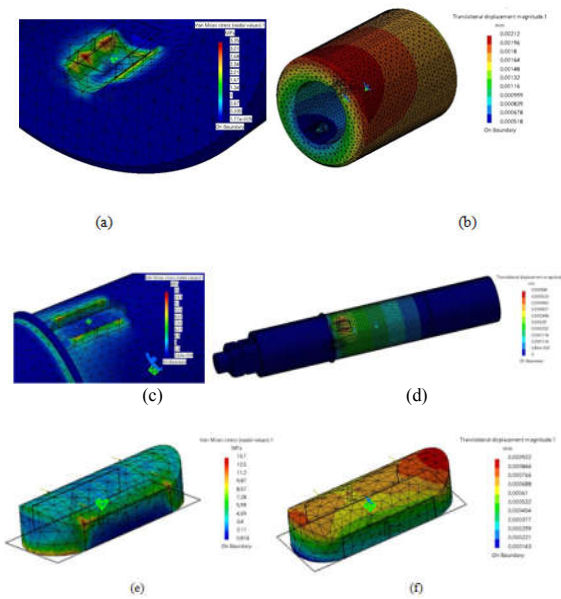

Figure 5. CAE simulation of the proposed encapsulated roller kit: (a) initial Von Mises stresses on the cover; (b) initial displacement of the cover in mm; (c) initial Von Mises stresses on the axis; (d) initial displacement of the shaft in mm; (e) initial Von Mises stresses on the key; (f) initial displacement of the key in mm

The main aspects of the new design of this tool, which allow it to outperform the existing version, are the insert cover itself, which is the element that is subject to wear and therefore needs to be periodically replaced, and the material of the shaft (core), which is less noble than the material of the cover (which is the same as for the one-piece tool), thus further reducing the cost of the parabolic leaf spring manufacturing process.

Drafting and optimization of the encapsulated roller kit: After analyzing the current scenario and its nuances, the preliminary design for the new encapsulated roller kit was created. In our initial approach, we used AutoCAD 2005 software from Autodesk. In this phase, the preliminary design of the new tool was compared with current physical sets through dimensional analysis. Further modeling and CAE simulation were carried out using CATIA V5 software. Insertion of parameters, an FEA analysis of the static behavior of the tool and optimization of the tool design were carried out in order to validate the model. 2D design detailing, in order to build the prototype, was obtained through optimization. The 'Generative Structural Analysis environment was used for CAE simulations, and the Product Engineering Optimizer module was used for product optimization. The mesh parameters used are shown in Table 1.

Table 2. Optimization results

Process	Best (MPa)	Max. Von Mises (MPa)	Load (N)
0	122.33	122.33	10,000.00
1	122.38	122.38	10,003.70
2	122.44	122.44	10,008.87
3	122.53	122.53	10,016.12
4	122.65	122.65	10,026.26
5	122.83	122.83	10,040.47
6	123.07	123.07	10,060.35
7	123.41	123.41	10,088.19
8	123.89	123.89	10,127.16
9	124.55	124.55	10,181.73
10	125.49	125.49	10,258.12
11	126.79	126.79	10,365.06
12	128.62	128.62	10,514.78
13	131.19	131.19	10,724.39
14	134.77	134.77	11,017.84
15	139.79	139.79	11,428.67
16	146.82	146.82	12,003.84
17	156.67	156.67	12,809.07
18	170.44	170.44	13,936.40
19	189.73	189.73	15,514.65
20	216.74	216.74	17,724.21
21	254.55	254.55	20,817.60
22	254.55	307.48	25,148.33
23	254.55	242.17	19,804.48
24	254.55	239.28	19,567.98
25	254.55	240.68	19,682.62
26	254.55	243.59	19,920.79
27	247.66	247.66	20,254.24
28	247.66	253.37	20,721.06
29	247.66	255.34	20,882.34
30	247.66	254.62	20,823.01
31	247.66	253.60	20,739.95
32	252.18	252.18	20,623.67
33	250.19	250.19	20,460.87
34	250.19	247.40	20,232.95
35	250.19	248.00	20,281.52
36	250.19	248.83	20,349.51
37	249.99	249.99	20,444.71
38	249.99	251.62	20,577.98
39	249.99	253.18	20,705.46
45	249.99	252.59	20,657.09
46	249.99	252.39	20,640.89
46	249.99	122.38	10,003.70
47	249.99	249.99	20,444.71

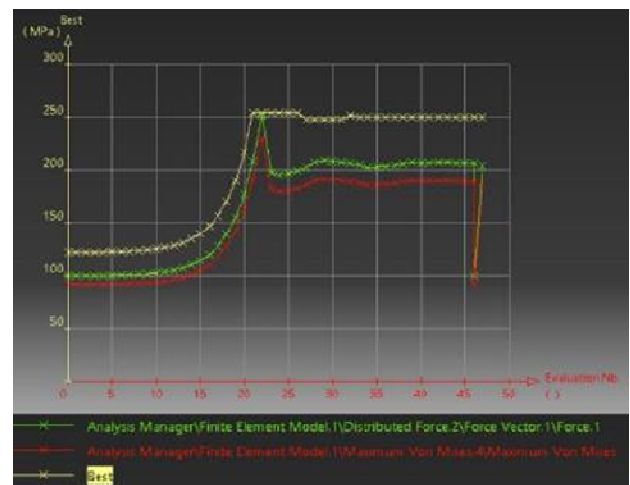

Figure 6. Curves obtained from the optimization process

A parabolic tetrahedral solid element was adopted for all components. Figure 3 shows the optimization tool of the Product Engineering Optimizer module. The optimization was configured to reach a maximum value of 250 MPa for the connecting element, in steps of 20N. The loads acting on this component were therefore varied throughout the process in such a way as to reach the optimum value.

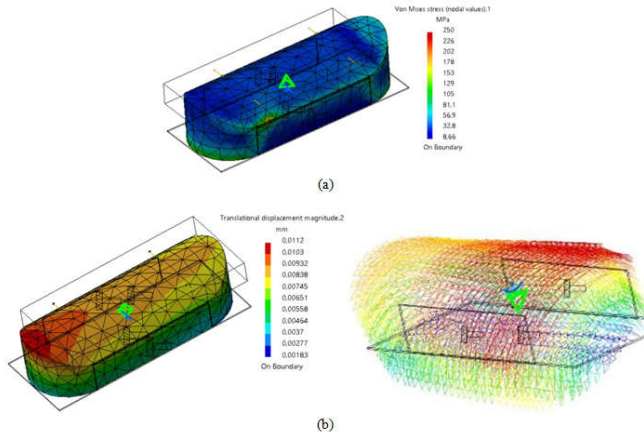

Figure 8. New geometry after the optimization process

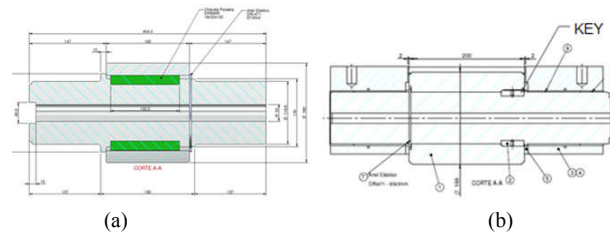

Figure 9. Conceptual design of the validated capsulated kit, after CAE simulation: (a) before the simulation, with a long key and a rectangular profile; (b) after the simulation, in which the length of the key was reduced and the profile was streaked on one of the tops

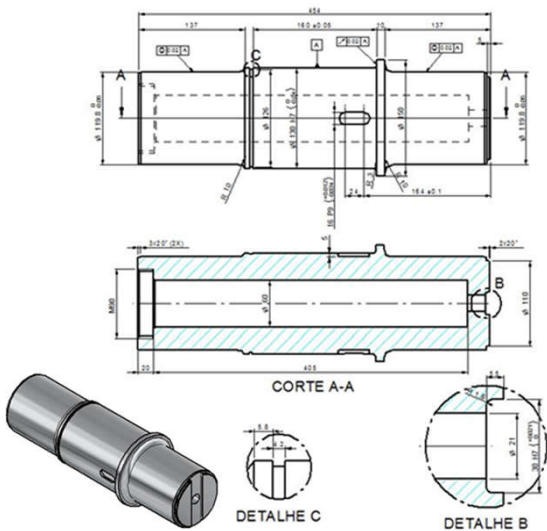

Figure 10. Transmission shaft (core) of the proposed tool, in SAE 8620 steel

The first idea was the insertion of a key into the shaft and cover interface. Figure 4 illustrates the initial design. Based on this concept, new studies were carried out in which changes were made to the geometry of the key. The initial proposed conditions were used to perform CAE simulation. Figure 5 illustrates the behavior of the encapsulated roller kit, in which the level of tension was gradually varied with the aim of producing an optimized tool for use in a production environment. To do this, fixed connections were placed between the key, shaft and cover elements. Figures 5a and 5b illustrate in detail the points of greatest stress concentration on the cover and the behavior in terms of displacement. Figures 5d and 5e show the details of the shaft housing. The key is shown in Figures 5f and 5g.

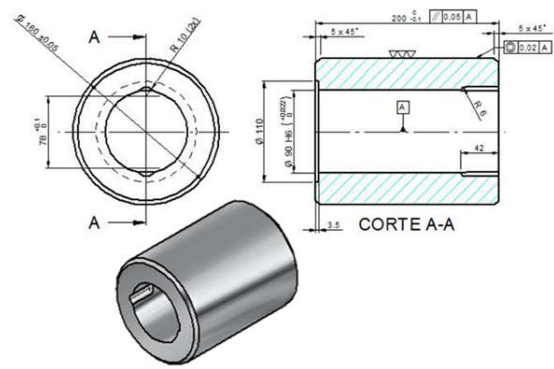

Figure 11. Cover (insert) of the proposed tool, in Bohler W360 steel

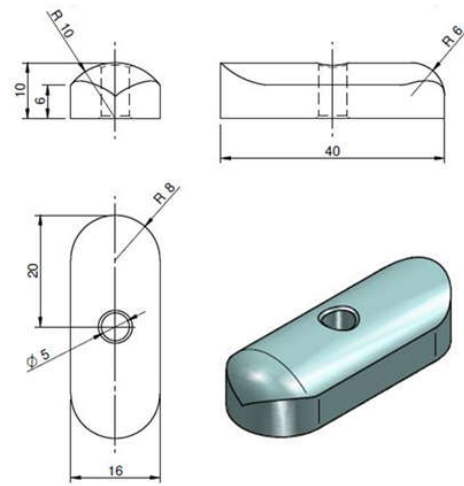

Figure 12. Assembly integration key for the proposed tool, in SAE 5160 steel

The optimization process gave a maximum load of 20,445N acting on the key as the final result. Figure 6 shows the curves obtained from the optimization process, and Table 2 summarizes the results. The optimization process hit the optimal size of the key in relation to the efforts worked by it. Figure 8a illustrates the Von Mises stresses in the key, and Figure 8b shows their respective displacements. Figure 9 shows the final set geometry. Figures 10, 11 and 12 show the details of the shaft (core), cover (insert) and key (transmission) components of the encapsulated roller kit set, respectively, after validation of the 3D model using CAE simulation. Based on the results of the analysis, the encapsulated roller kit was built from the 2D design and was tested in a production environment under the same operational conditions as the original tool, with the basic assumption of a minimum lifetime of 15 days of uninterrupted operation on a 24-hour basis. At the end of 30 days of assisted production, the functional characteristics of the new tool were preserved, meaning that it could continue in operation. Since the original (one-piece) tool was imported from Germany, it was more expensive and had a high lead-time for delivery; this required a high reserve stock to be maintained, for which the capital cost was not negligible. Our proposed encapsulated roller kit could be made locally, thus reducing both the acquisition cost (from BRL 30,000 to BRL 10,000) and the inventory, which had an average value of BRL 120,000 (equivalent to four tool sets). It was observed that the quality of the product created with our proposed encapsulated roller kit was equivalent to that from the original tool. The simplified geometry of the encapsulated roller kit preserved the core of the tool when in operation, reducing the need for replacement due to wear of the insert element (cover) and not only extending the service life of the tool core but also ensuring the process capability. The rolling cycle time with the modified tool was the same as for the original one, where as the service life of the new tool was twice that of the original.

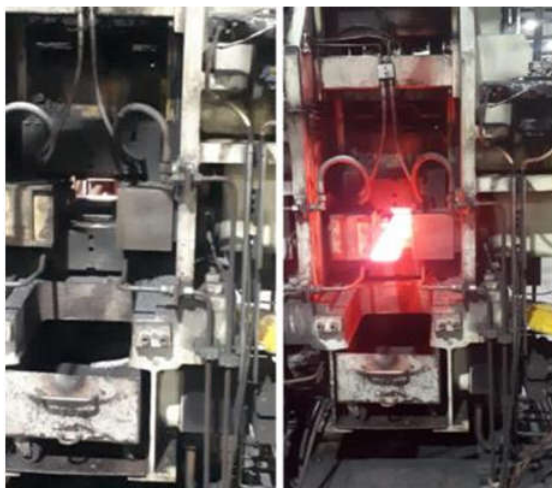

Figure 13. Implementation of the final study in the factory

The roller cover used with the modified tool allowed the time of exposure in production to exceed that of the original tool, which was discarded after reaching the maximum tolerable wear of 7mm in its thickness. The behavior of the new tool in assisted production demonstrated the robustness of its design, and confirmed the efficiency and effectiveness of the CAE simulation software. Another benefit that was observed was a reduction in the energy consumption of the tool making process (for replacement due to wear), since only the back cover (10kg) needed to be manufactured rather than the entire roller (52kg). The implementation of the new process is illustrated in Figure 13. Finally, it is worth noting the environmental benefits that were achieved by reducing the consumption of both steel and energy.

CONCLUSION

Using CAE simulation, we were able to predict the behavior of a new tool that was designed for a rolling process, which provided a reduction in the development time and tooling cost while ensuring the quality of the rolled product. The new concept, which we called an encapsulated roller kit, was implemented under the same working conditions as the original tool (a one-piece roller). Our new tool proved to be more efficient and effective, since the use of a roller cover extended the exposure time of the tool in production, while preserving the cycle time and process capability.

The behavior of the new tool in a production environment was monitored on a daily basis through visual and dimensional controls. From an economic point of view, the tooling costs were reduced by 66%. With regard to the environmental benefits, the energy consumption required for the manufacture of the roller was reduced, since only the back cover needed to be manufactured for replacement rather than the entire tool.

Acknowledgments

José de Souza thanks God, who has given him such great and special academic and professional experiences. God is a great inspiration and teacher, and José dedicates his whole life to Him. He also thanks his wife, Josevania Lopes de Souza, and his daughters, Giovanna Lopes de Souza and Lara Lopes de Souza, who are the reason for his life. Thanks are due to the Faculty SENAI of Mechatronic Technology for its creative and rich environment in terms of academic and technological resources, and its entire faculty. The authors would like to thank THYSSENKRUPP Brazil Division, Springs & Stabilizers, and Eng. Ercio Souza Secchi, for his contribution to structuring this project.

REFERENCES

- Autodesk. "AutoCAD 2005. Software de desenho 2D desenvolvido em 2005." Available from: <https://www.autodesk.com.br/products/autocad/overview?term=1-YEAR&support=null>. Accessed on: 28 Sept. 2020.
- Cetlin, P. R. and Helman, H. 2005. *Fundamentos da Conformação Mecânica dos Metais*. 2nd ed. São Paulo, SP: Artliber.
- Dassault Systèmes. "Catia V5. Software de simulação 3D desenvolvido em 2000." Available from: <https://www.3ds.com/products-services/catia/products/>. Accessed on: 20 Nov. 2020.
- Jurgens, U. Toward new product and process development networks: the case of the German Car Industry, In: Jurgens, U. New product development and production networks. Berlin: Springer-Verlag, 2000. https://doi.org/10.1007/978-3-662-04255-7_11
- Oliveira, W. B. and Ferreira, A. R. 2016. "Análise de projetos mecânicos utilizando ferramenta de simulação CAE," *REMIPE- Revista de Micro e Pequenas Empresas e Empreendedorismo da Fatec Osasco*, vol. 1, no. 2.
- Siemens. "CAE/Engenharia Auxiliada por Computador." Available from: http://www.plm.automation.siemens.com/pt_br/plm/cae.shtml. Accessed on: 13 Nov. 2015.
