



## Full Length Review Article

### DESIGN AND MATERIAL ANALYSIS OF BELT SHIFTER ASSEMBLY FOR ENHANCING THE BELT LIFE WITH LEGATO MOVEMENT OF OVER HEAD TRAVELLING CLEANER

**\*Sathish Kumar P. and Sathish Kumar K.**

Department of Mechanical Engineering, United Institute of Technology, Coimbatore-641020, India

#### ARTICLE INFO

##### Article History:

Received 15<sup>th</sup> April, 2016  
Received in revised form  
26<sup>th</sup> May, 2016  
Accepted 14<sup>th</sup> June, 2016  
Published online 31<sup>st</sup> July, 2016

##### Key Words:

OHTC, PU,  
Nylon,  
Weaving,  
Roving.

#### ABSTRACT

The OHTC (Over Head Travelling Cleaner) is a textile cleaning unit which is used in all textile frames such as spinning, speed frame, weaving, roving, winding etc. The main function of the OHTC unit is used to clean the cotton waste, bluffs and prevents them entering into the frames of the machines to produce fine threads for different application purpose. The Belt Shifter assembly is considered as the heart of OHTC unit, which is used to shift the belt frequently for to and fro motion of the unit. Polyurethane is the material used in Belt shifter unit. Material breakage, breakdown of the whole unit, frequent belt damage are some of the problems faced in using the polyurethane material. The analysis of the above material was carried out based on the properties and some design modification was done. A new material (Nylon) was selected based on the drawback of the old material and design modification was done on the material for rigidity and strength to resist high shear stress on the material. The 3-D modeling was carried out by CATIA V5R20 the analysis of shear force between the belt shifter and the reversing spring were carried out by means of ANSYS 14.5.

*Copyright©2016, Sathish Kumar and Sathish Kumar. This is an open access article distributed under the Creative Commons Attribution License, which permits unrestricted use, distribution, and reproduction in any medium, provided the original work is properly cited.*

#### INTRODUCTION

The selection of material in day today life is a tedious process based on the performance, longer life and well as the economic cost analysis. Though we have lot of advantages in using polyurethane material, for the specific function such a sliding, as well as to withstand high load, PU material fails to undergo function of the sliding and breaks at very low load as in case of Belt shifter assembly. Lot of material were analyzed, but it was found that material Nylon has a good sliding properties and also good abrasion resistant. Due to many favourable properties of Nylon, it has been selected for the Belt Shifter parts.

#### Literature Survey

**Polyurethane:** Mr. K. Maji, M.ASCE, (Assoc. Prof., Dept. of Civ. Engg., Univ. of New Mexico, has done a experimental Investigation of Tensile Fracture in polyurethane foams and found the failure result due to its stress factor in the Journal of Materials in Civil Engineering. Polyurethane has been used for their shock-absorption properties in various packaging

*\*Corresponding author: Sathish Kumar P.,  
Department of Mechanical Engineering, United Institute of  
Technology, Coimbatore-641020, India.*

applications. In many light-weight structural applications, polyurethane foams are used as the core material in sandwich beams or in panel construction. The mechanical properties of these foams have come under increased scrutiny because of their application to nuclear-waste shipment packages, and their use as "bone stimulant" in testing orthopedic implants. This paper describes a number of tests performed on polyurethane foams of various densities to understand their tensile fracture characteristics. D. Kip Hillshafer, Research Associate; Michael E. O'Brien, Ph.D., Senior Research Chemist; and Eric J. Geiger, Senior Product Development Chemist, Univ. of Technion, has done a test on dynamic fracture toughness of polyurethane foam and studied the effect of impregnation on the fracture toughness.. This paper is a first attempt to determine the dynamic fracture toughness of polyurethane foam and to study the effect of impregnation on the fracture toughness. Instrumented impact tests were performed using notched specimens. In order to study the effect of impregnation on the impact properties two different resins were used. Liviu Marsavina, Tomasz Sadowski, Dan Mihai Constantinescu, Radu Negru were the author of Key Engineering Materials (volumes 385 – 387) page 205-208. This paper deals about Failure of polyurethane foams under different loading conditions. Polyurethane foam materials are widely used as cores in sandwich composites, for packing and

cushioning. This paper presents the experimental results obtained for the mechanical properties of polyurethane foams in different loading conditions and the influence of impregnation on the mechanical properties.

## Nylon

Dr. D. Prevorsek, R.H. Butler, Allied Chemical Corporation Corporate Chemical Research Laboratory, Morristown, N.J on International Journal of polymeric materials ,page 251 – 277 studied about the structure of Nylon-6 from analysis of viscoelastic properties . A method is outlined to study the structure property relationship in semicrystalline fibers involving (a) the characterization of structure in terms of the two phase amorphous-crystalline model (size, concentration and orientation of the crystallites, etc.), (b) the analysis of viscoelastic responses in terms of Takayanagi models, and (c) the analysis of diffusion assuming that crystals are essentially impermeable to large dye molecules.

## Belt shifter assembly

The Belt shifter assembly consists of following parts

- Shifter
- Base
- Compression spring
- Iron ball
- Ball cap
- Washer
- Switch fork

Here Shifter and Base are the material made up of polyurethane. For the remaining material alteration were made based on the functionality and better performance. These alteration were made using Auto CAD and was fitted in the assembly part and trial run was carried out and found only 20% favourable result. Some of the problem incurred in using polyurethane materials is listed below

- Shifter gets broken often.
- It damages the reversing springs.
- The OHTC machine which has to run 24 hrs per day remains idle for few hours or days based on replacement of shifter.
- Firing of cotton waste.
- Belt gets damaged often.
- More labours are required to clean the waste manually if not replaced.

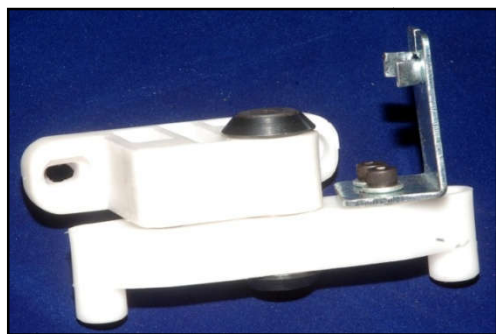

Fig. 1. Pu Belt Shifter Assembly

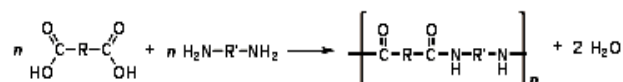

Fig. 2. Belt Shifter Assembly in OHTC Unit

Fig-1 shows the Belt Shifter assembly made of polyurethane material. Fig-2 shows the belt shifter assembly in the machine unit.

## Generalized reaction for Nylon and Polyurethane

### General condensation polymerization reaction for Nylon



Subsequently polyamides 6, 10, 11, and 12 have been developed based on monomers which are ring compounds; e.g. caprolactam. nylon 66 is a material manufactured by condensation polymerization. Nylons still remain important plastics, and not just for use in fabrics. In its bulk form it is very wear resistant, particularly if oil-impregnated, and so is used to build gears, plain bearings, and because of good heat-resistance, increasingly for under-the-hood applications in cars, and other mechanical parts.

### Generalized Polyurethane Reaction

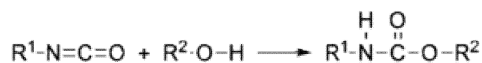

Polyurethanes are in the class of compounds called reaction polymers, which include epoxies, unsaturated polyesters, and phenolics. A urethane linkage is produced by reacting an isocyanate group,  $-\text{N}=\text{C}=\text{O}$  with a hydroxyl (alcohol) group,  $-\text{OH}$ . Polyurethanes are produced by the polyaddition reaction of a polyisocyanate with a polyalcohol (polyol) in the presence of a catalyst and other additives. In this case, a polyisocyanate is a molecule with two or more isocyanate functional groups,  $\text{R}-(\text{N}=\text{C}=\text{O})_{n \geq 2}$  and a polyol is a molecule with two or more hydroxyl functional groups,  $\text{R}'-(\text{OH})_{n \geq 2}$ . The reaction product is a polymer containing the urethane linkage,  $-\text{RNHCOOR}'-$ . Isocyanates will react with any molecule that contains active hydrogen. Importantly, isocyanates react with water to form a urea linkage and carbon dioxide gas. They also react with polyetheramines to form polyureas. Commercially, polyurethanes are produced by reacting a liquid isocyanate with a liquid blend of polyols, catalyst, and other additives. These two components are referred to as a polyurethane system, or simply a system.

### Effect of using polyurethane material

The broken PU material from the mill was displayed in the figure.



Fig. 3. Broken Pu –Material with Shifter Fork

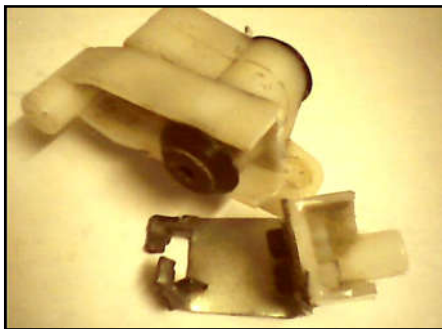

Fig. 4. Broken PU- material with damaged Shifter Fork assembly

### Properties of PU and Nylon

#### Properties of Nylon

All Nylon 6/6 materials have high mechanical strength and superior resistance to wear and organic chemicals. NYLON 6/6 GF30 has more than double the strength and stiffness of unreinforced nylons and a heat deflection temperature which approaches its melting point. NYLON 6/6 is a 30% glass-fiber-reinforced nylon 6/6 material whose important properties includes high tensile and flexural strength, stiffness, excellent heat deflection temperature, and superior abrasion and wears resistance.

- very good physical properties
- moisture has significant effect on properties
- very good heat resistance
- excellent chemical resistance
- excellent wear resistance
- moderate to high price
- fair to easy processing
- Glass transition temperature: 50°C.
- Melting temperature: 255°C.
- Amorphous density at 25°C: 1.07 g/cm<sup>3</sup>.
- Crystalline density at 25°C: 1.24 g/cm<sup>3</sup>.
- Molecular weight of repeat unit: 226.32 g/mol.

### Properties of polyurethane

- It is less stable than polyamides.
- It is easily affected by moisture.
- It has very low thermal conductivity of 0.209kJ/kg.
- Percentage elongation at breakage is very low.
- Izoid impact is around 0.8 to 1.
- Low density and flexible.
- Very low elastic modulus.
- Cohesion of molecules is low.
- Elongation at break is around 100 to 1000.
- Specific gravity is very low.
- Melting temperature is low.

Comparing the above properties of Nylon and Polyurethane, Nylon was found to give favourable result for legato movement of OHTC.

### 3-D Model using catia V5R20

The 3-D model was designed using CATIA V5R20. In the shifter part a rib was provided to resist bending. Fig shows the old and new design of belt shifter assembly. In the old design very low tolerance was given for the shifter hole such that the bush enters the shifter hole under some load, but in new design the hole was provided based on the tolerance given for the bush so that the threaded bush enters the shifter hole easily without any load

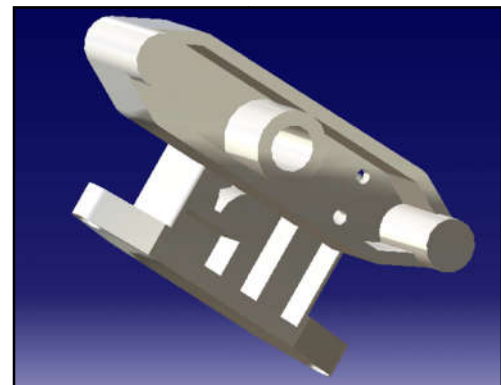

Fig. 5. Old Belt Shifter Design

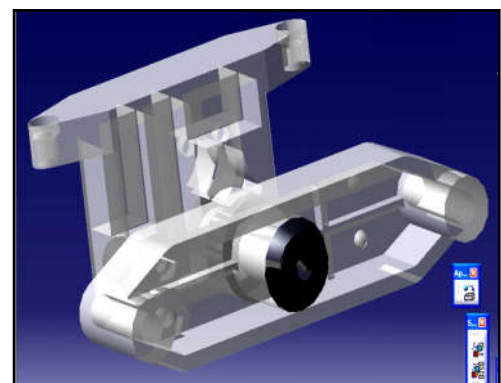

Fig. 6. Modified Belt Shifter Design using CATIA V5R20

Analysis

ANSYS

Comparative study of the belt shifter assembly was done in Ansys between polyurethane and Nylon materials and it was found that the Nylon withstand high stress load when compared to polyurethane. Also the factor of safety was favourable in case of nylon materials. The elastic strain was found to be high in case of nylon materials and low in case of polyurethane. The following figure shows the comparative study of polyurethane and nylon materials based on stress, strain and the factor of safety for more favourable result of nylon. Hence we conclude that the nylon material has most favourable property for sliding function and cost reduction than polyurethane.

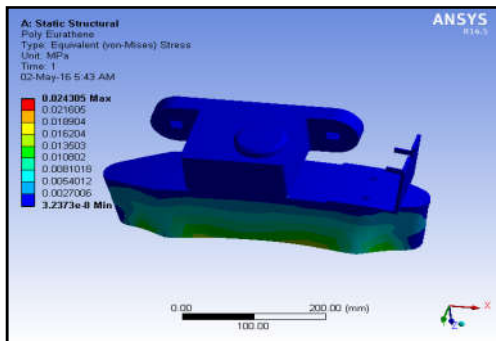

Fig. 7. Stress Distribution of PU during Von-Mises Stress

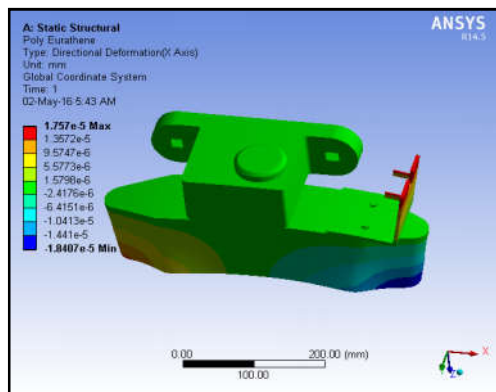

Fig. 8. Stress Distribution of PU during Directional Deformation

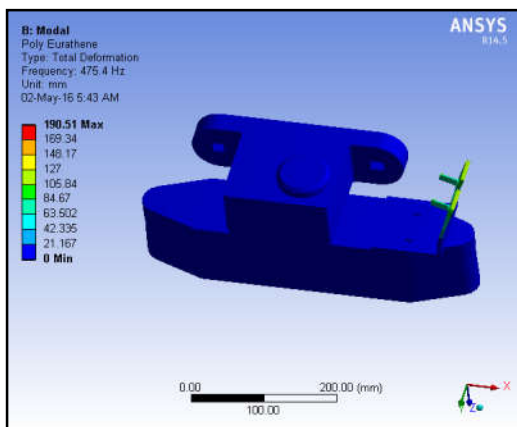

Fig-9: Total Deformation of PU at Maximum Vibration

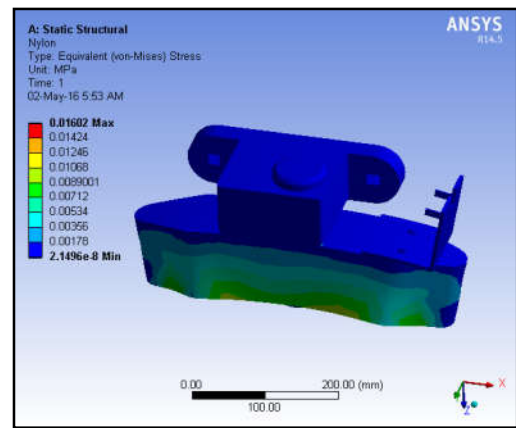

Fig. 10. Stress Distribution of Nylon during Von-Mises Stress

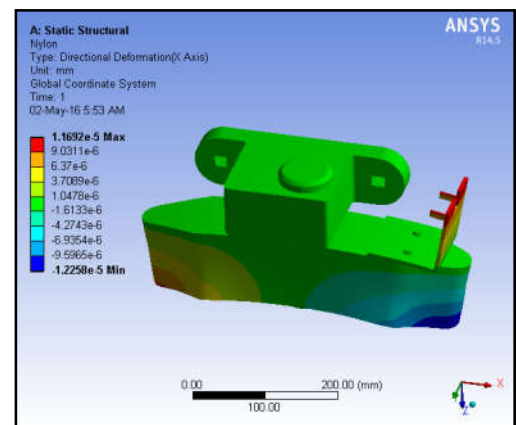

Fig. 11. Stress Distribution of Nylon during Directional Deformation

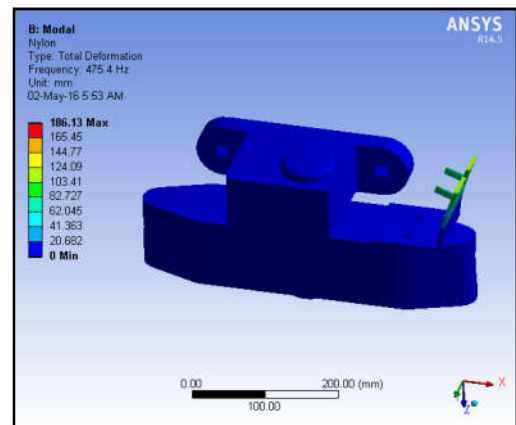

Fig. 12. Total Deformation of Nylon at Maximum Vibration

Stress Ratio

The most commonly used stress ratio is R, the ratio of the minimum stress to the maximum stress ( $S_{min}/S_{max}$ ). If the stresses are fully reversed, then  $R = -1$ . If the stresses are partially reversed,  $R =$  a negative number less than 1. If the stress is cycled between a maximum stress and no load,  $R =$  zero. If the stress is cycled between two tensile stresses,  $R =$  positive number less than 1. Variations in the stress ratios can significantly affect fatigue life. The presence of a mean stress component has a substantial effect on fatigue failure.

When a tensile mean stress is added to the alternating stresses, a component will fail at lower alternating stress than it does under a fully reversed stress. Material analysis were carried out by Ansys 14.5 and found that the deformation produced on PU material is high for the same load carried out on Nylon.

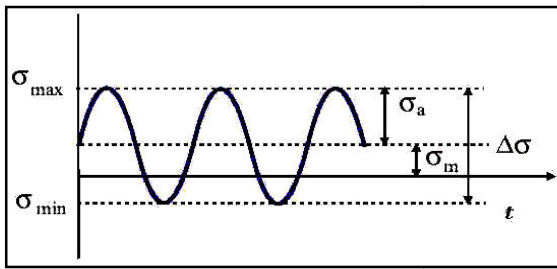

Fig. 13. Maximum and Minimum Stress for Different Loading Condition

## RESULTS AND COMPARISSON

Description	Polyurethane	Nylon
Von – Misses Stress	0.024305mm	0.01602mm
Directional Deformation	1.757e-5mm	1.1692e-5mm
Total Deformation at Maximum Vibration (475.4Hz)	190.51mm	186.13mm

## Conclusion

It is obvious that, from the above study based on properties, generalized reaction and analysis of Polyurethane and Nylon, PU material lags some property against the smooth function of Belt Shifter parts. Nylon material was found to have good mechanical property which can withstand high stresses, low deformation from the above study and analysis for legato movement of Over Head Travelling Cleaner.

## REFERENCES

- Bates, P.J., J.J. MacDonald, C. 2003. Y. Wang, H. Liang Vibration Welding Nylon 66- Part II Finite Element Analysis -Journal of Thermoplastic Composite Materials, Vol. 16, No. 3, 197-211 DOI:10.1177/0892705703016003001.
- Egorov, E. A., V. V. Zhizhenkov, P. M. Pakhomov, A. S. Chegolya, November 1992. Microprocesses Accompanying Deformation of Oriented Nylon 6 - Volume 18, Issue 3 & 4 - 12 issues per year- A. F. Ioffe Physical Technical Institute, Academy of Sciences of Russia, St. Petersburg, Russia.
- Maji, K., M. Asce, (Assoc. Prof., Dept. of Civ. Engrg., Univ. of New Mexico, Albuquerque, NM 87131), D. Satpathi, (Res. Asst., Dept. of Civ. Engrg., Univ. of New Mexico, Albuquerque, NM), and S. Donald, (Res. Asst., Dept. of Civ. Engrg., Univ. of New Mexico, Albuquerque, NM), Experimental Investigation of Tensile Fracture in Polyurethane Foams - *Journal of Materials in Civil Engineering*, Vol. 7, No. 4, November 1995, pp.258-264, 10.1061/(ASCE)0899 561(1995)7:4.
- Thomas Davidson- an Introduction to Failure Analysis for Metallurgical Engineers-1998-vol-2
- Modal analysis of a distributed parameter rotating shaft, Volume 122, Issue 1, 8 April 1988, Pages 119–130.
- Cawley, P. and Adams, R. D. 1979. "Location of defects in structures from measurements natural frequencies", *Journal of Strain Analysis for Engineering Design*, Vol. 14, pp. 49-57.
- Marc Taub, Glenn Wera, Reinhold H.Dauskard-sep-2004-failure of medullary tubes-a material analysis-volume 35, Issue-9, page 878-882.
- Charles W. Fowlkes Monday, January 17, 2005. Fracture toughness tests of a rigid polyurethane foam- *International Journal of Fracture*-vol 10, number 1/march, 1974, page no-99-108.

\*\*\*\*\*